

PRIMO INOX stainless steel version 990 kg - Low voltage control, single phase

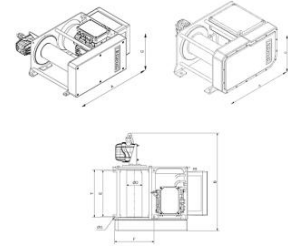
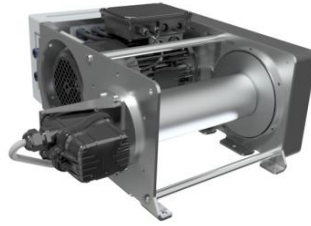

- Range of electric winches designed for simple lifting and pulling applications in a corrosive environment.

Technical properties

- Very low voltage control ensuring user protection against electric risks.
- Rigid stainless steel aluminium structure (316 L).
- Up--down pendant control with emergency stop, not removable, cable 3 m long, IP 66. Marine type electric cable (without halogen). Harting type plug, IP 66.
- IP 66 control box.
- Single-phase motor brake 230 V - 50 Hz lifting type, P = 0.75 kW. Isolation class F. IP 66.
- Reducer in oil bath with helical gears.
- Mechanically welded drum with wide flanges allowing a secure fastening of the wire rope.
- Limit switches included (IP 66/67).
- Rope-press roller and grooved drum as optional equipment.

Technical characteristics of PRIMO INOX stainless steel version 990 kg - Low voltage control, single phase

References	PRIMO991BT4INOX
Capacity 1st layer kg	990
Capacity top layer kg	990
Nb of layers	3
Wire rope cap. 1st layer m	11
Max. rope capacity m	42
Wire rope Ø mm	10
Speed 1st layer m/mn	4
Speed top layer m/mn	5,2
FEM	1Bm
Motor kW	1,1
Power	1Ph-230V

Weight (without cable) kg	90
---------------------------	----

Dimensions

References	PRIMO991BT4INOX
A mm	580
B mm	615
C mm	326
D mm	140
E mm	260
F mm	280
G mm	17
T mm	280

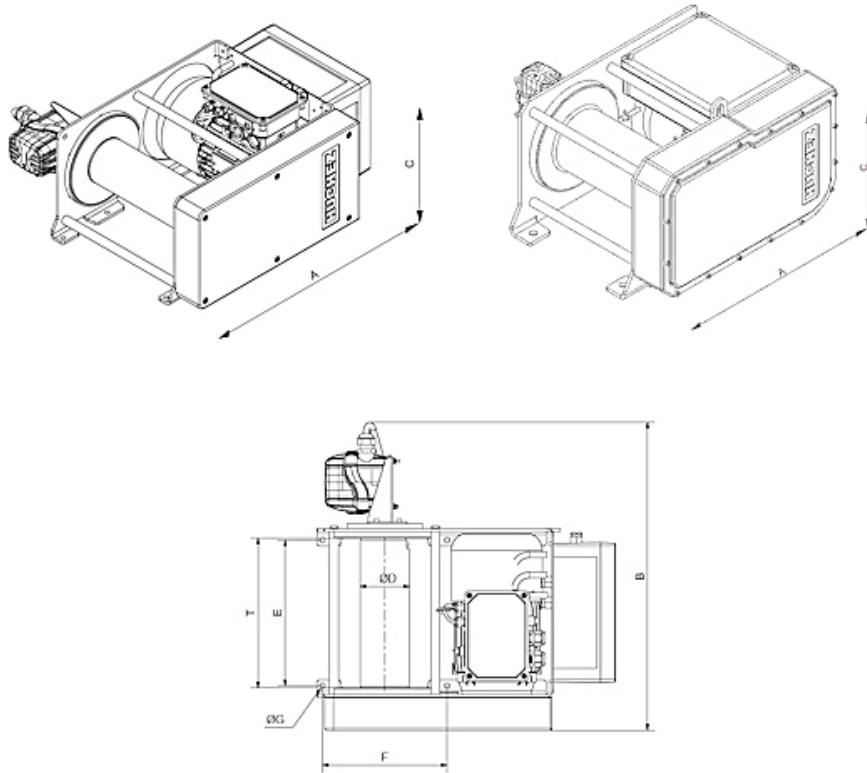

Technical characteristics of the other models of the range

References	PRIMO251BT8INOX	PRIMO401BT6INOX	PRIMO993BT4INOX	PRIMO253BT8INOX	PRIMO403BT6INOX
Capacity 1st layer kg	300	400	990	300	400
Capacity top layer kg	250	400	990	250	400
Nb of layers	4	3	3	4	3
Wire rope cap. 1st layer m	13	6	11	13	6
Max. rope capacity m	63	39	42	63	39
Wire rope Ø mm	5	6,2	10	5	6,2
Speed 1st layer m/mn	7,7	6,2	4	7,7	6,2
Speed top layer m/mn	10,3	8	5,2	10,3	8
FEM	1Bm	1Bm	1Bm	1Bm	1Bm
Motor kW	0,75	0,75	1,1	0,75	0,75
Power	1Ph-230V	1Ph-230V	3Ph-230/400V	3Ph-230/400V	3Ph-230/400V
Weight (without cable) kg	40	40	90	40	40

References	PRIMO991BT4INOX
Capacity 1st layer kg	990
Capacity top layer kg	990
Nb of layers	3
Wire rope cap. 1st layer m	11
Max. rope capacity m	42
Wire rope Ø mm	10
Speed 1st layer m/mn	4
Speed top layer m/mn	5,2
FEM	1Bm
Motor kW	1,1
Power	1Ph-230V
Weight (without cable) kg	90



HUCHEZ
 4, rue Michel HAMMID
 60420 FERRIERES – France
 +33 (0) 3 44 51 11 33
www.huchez.com
contact@huchez.fr



SERVICE CLIENTS
 ATENCIO AL CLIENTE
 KUNDENSERVICE



Pour en savoir plus, n'hésitez pas à nous contacter!
 To know more, please contact us!
 Para más información, póngase en contacto con nosotros!
 Für weitere Informationen können Sie sich gerne an uns wenden!